

# TECHNICAL DATA SHEET



**IRIS S8**  
(PIR Motion Sensor)



The product adopts good sensitivity detector and integrated circuit. It gathers automatism, convenience, safety, saving-energy and practical functions. It utilizes the infrared energy from human as control-signal source and it can start the load at once when one enters detection field. It can identify day and night automatically. It is easy to install and used widely

## TECHNICAL SPECIFICATION

Power Source:	110-240V/AC
Power Frequency:	50/60Hz
Detection Range:	360°
Detection Distance:	8m max(<24°C)
Ambient Light:	<3-2000LUX (Adjustable)
Hold Time:	Min. 10Sec±3Sec, 7Min±2min
Working Temperature:	-20°C~+40°C
Working Humidity:	<93%RH
Power Consumption:	Approx 0.5W
Rated Load:	400W (220-240V/AC), 200W (110-130V/AC) (Incandescent), 200W (220-240V/AC), 100W (110-130V/AC) (LED Load)
Installation Height:	3.5m
Detection Moving Speed:	0.6-1.5m/s

## FUNCTION

- Can identify day and night: The consumer can adjust working state in different ambient light. It can work in the daytime and at night when it is adjusted on the "sun" position (max). It can work in the ambient light less than 3LUX when it is adjusted on the "moon" position (min). As for the adjustment pattern, please refer to the testing pattern.
- Time-Delay is added continually: When it receives the second induction signals within the first induction, it will restart to time from the moment.

## INSTALLATION

- 1) Avoid pointing the detector towards objects with highly reflective surfaces, such as mirrors etc.
- 2) Avoid mounting the detector near heat sources, such as heating vents, air conditioning units, light etc.
- 3) Avoid pointing the detector towards objects that may move in the wind, such as curtains, tall plants etc.
- 4) Please move the upper cover with anti-clockwise whirl as per the diagram on the right.
- 5) Connect the power and the load according to the connection-wire diagram.
- 6) Fix the bottom on the selected position with the inflated screw.
- 7) Install back the upper cover on the sensor, then you could switch on the power and test it.

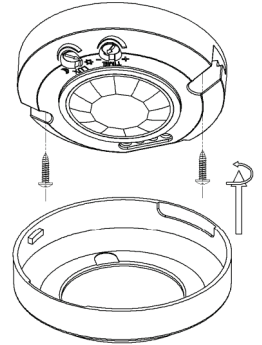
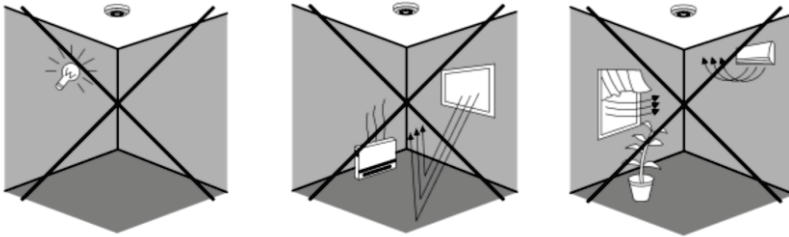

## CONNECTION WIRE DIAGRAM APPLICATION

## PRODUCT SIZE DIAGRAM

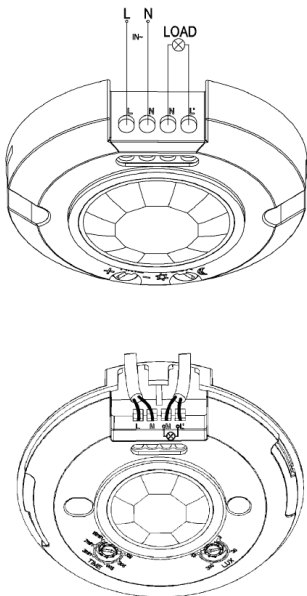

Note: When testing in daylight, please turn LUX knob to (SUN) position, otherwise the sensor could not work!

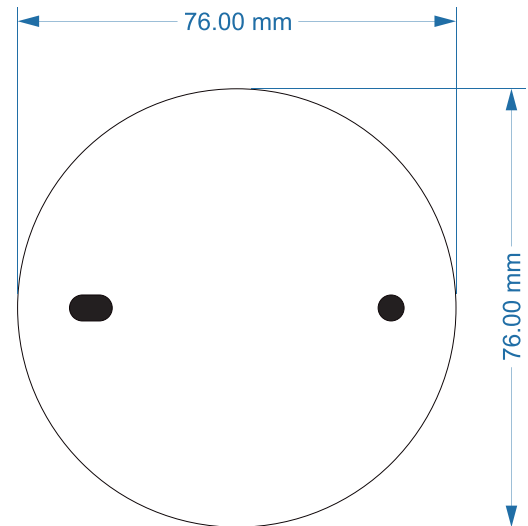

## CALIBRATION

- 1) Sensitivity:** The light can be set to stay ON for any period of time between approx. 10sec(turn fully anticlockwise) and a maximum of 12min(turn fully clockwise). Any movement detected before this time elapse will re-start the timer. It is recommended to select the shortest time for adjusting the detection zone and for performing the walk test.
- 2) Time Setting:** The chosen light response threshold can be adjusted from <3-2000 lux. Turn it fully anti-clockwise to select dusk-to-dawn operation at about 2 lux. Turn it fully clockwise to select continuous daylight operation. The knob must be turned fully clockwise when adjusting the detection zone and performing the walk test in daylight, then adjust setting according to site requirement.

## TEST

- Turn the TIME knob anti-clockwise on the minimum (-). Turn the LUX knob clockwise on the maximum (sun).
- Switch on the power; the sensor and its connected lamp will have no signal at the beginning. After Warm-up 30sec, the sensor can start work. If the sensor receives the induction signal, the lamp will turn on. While there is no another induction signal any more, the load should stop working within  $10\text{sec} \pm 3\text{sec}$  and the lamp would turn off.
- Turn LUX knob anti-clockwise on the minimum (moon). If the ambient light is more than 3LUX, the sensor would not work and the lamp stop working too. If the ambient light is less than 3LUX (darkness), the sensor would work. Under no induction signal condition, the sensor should stop working within  $10\text{sec} \pm 3\text{sec}$

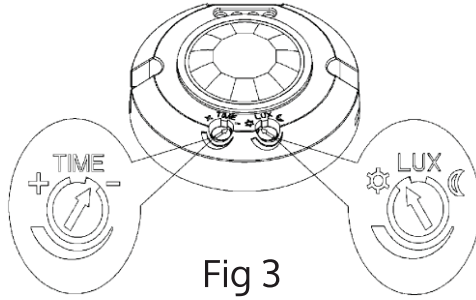

## APPLICATION

### ➤ Daylight Function

Hold time is set to 30 sec, Lux is set to 300 Light on when detect movement and off After people leave at leave at night. Applications: Corridor, Staircase.

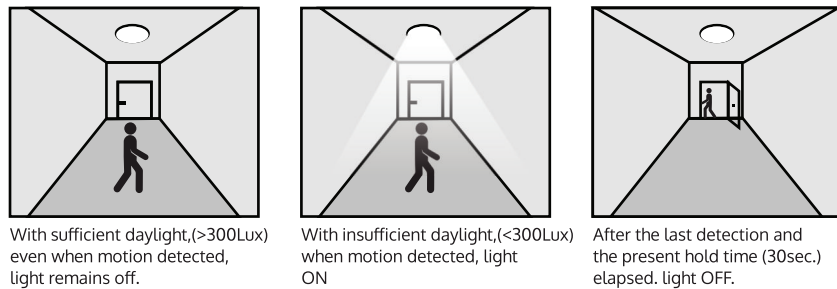

### ➤ No Daylight Function

The daylight threshold is set to or 2000 Disable Light on when detect movement, After people leave, Light off after hold time elapsed (30 Sec.) Applications: Dim places such as Basement Parking, Underpass.

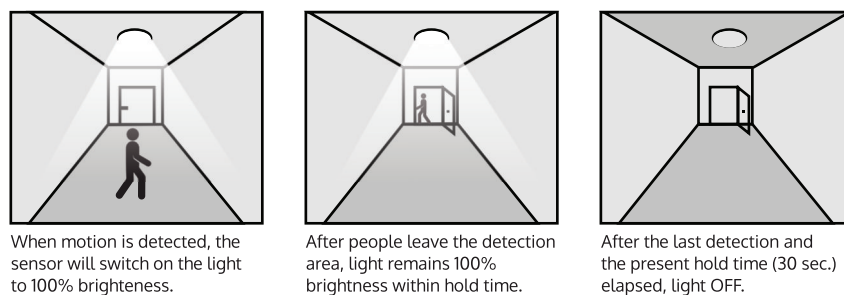

## NOTE

- Electrician or experienced human can install it.
- Can not be installed on the uneven and shaky surface
- In front of the sensor there shouldn't be obstructive object affecting detection.
- Avoid installing it near the metal and glass which may affect the sensor.
- For your safety, please don't open the case if you find hitch after installation.

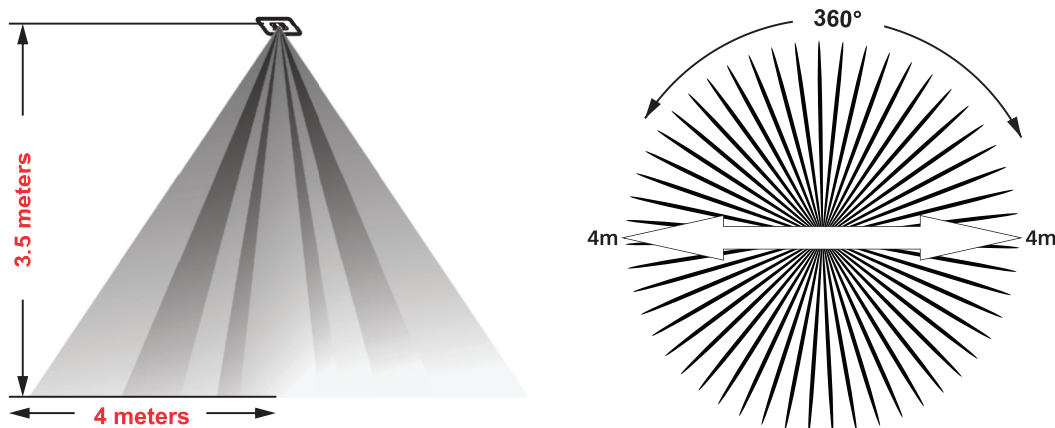

## TROUBLESHOOTING

Malfunction	Cause	Remedy
The load will not work	Wrong light control selected Load faulty Mains is switched OFF	Adjust Setting Change Load Switch ON
The load is always on	Continuous movement in detection zone	Check zone setting
The load is ON without any identifiable movement	The sensor not mounted for detecting movement reliably Movement occurred, but not identified by the sensor(movement behind wall, movement of a small object in immediate lamp vicinity etc)	Securely mount enclosure Check zone setting
The load will not work despite movement	Rapid movements are being suppressed to minimize malfunctioning or the detection zone you have set is too small	Check zone setting.

