

# TECHNICAL DATA SHEET



Download the Sensinova App

## IRIS S12W (PIR Motion Sensor)



The product adopts a good sensitivity detector and integrated circuit. It gathers automatism, convenience, safety, saving-energy, and practical functions. It utilizes the infrared energy from humans as a control-signal source and it can start the load at once when one enters the detection field. It can identify day and night automatically. It is easy to install and used widely. Moreover, it can be controlled by the Mobile.

### TECHNICAL SPECIFICATION

Voltage:	220-240 V AC
Power Frequency:	50 Hz
Luminance Detection:	Dark (5LUX), 10 LUX Evening (50LUX), 150 LUX, Day (2000 LUX)
Full Light Duration:	5s-60min (adjustable)
Power Consumption:	Approx 0.5W
Rated Load:	Max. 2000W 1000W
Detection Range:	360°
Motion Detection:	Low (50%), Middle (75%) High (100%) (choice)
Detection Distance:	8m max(<24°C)
Working Temperature:	-20~+40°C
Detection Moving Speed:	0.6-1.5m/s
Installation Height:	2.2-4m

### FUNCTION

- Can identify day and night: The consumer can adjust the working state in different ambient lights. It can work in the daytime and at night when it is adjusted to "Day". It can work in the ambient light less than 5LUX when it is adjusted to "Dark"
- Full light duration is added continually: When it receives the second induction signal within the first induction, it will restart to time from the moment. About the Motion Detection, Luminance detection, and Full light duration, please refer to the testing pattern



## INSTALLATION ADVICE

As the detector responds to changes in temperature, avoid the following situations:

- 1) Avoid pointing the detector towards objects with highly reflective surfaces, such as mirrors, etc.
- 2) Avoid mounting the detector near heat sources, such as heating vents, air conditioning units, light, etc.
- 3) Avoid pointing the detector towards objects that may move in the wind, such as curtains, tall plants, etc.

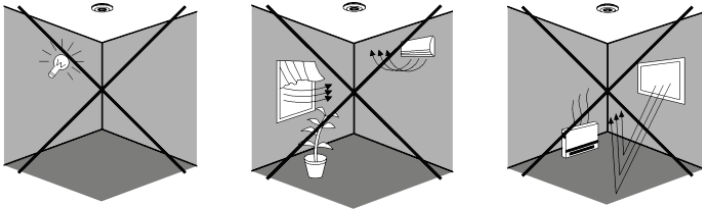

### WARNING

Warning. Danger of death through electric shock!

- ▶ Must be installed by professional electrician.
- ▶ Disconnect power source.
- ▶ Cover or shield any adjacent live components.
- ▶ Ensure device cannot be switched on.
- ▶ Check power supply is disconnected.

## SETTING

It can only be controlled by the mobile and needs to be connected with the WIFI. The factory mode is Motion Detection (Low), Luminance detection (Day), Full light duration (5S). About the details, see the steps below.

**Step 1:** Download the 'Sensinova Smart Switch' app, then log in with your mobile number or Email Address.

**Step 2:** Connect the product with the lamp, switch the power ON-OFF-ON-OFF-ON. Until the red indicator blinks.

**Step 3:** Open the app, click "Add Device" or click the top right corner "+", refer to picture 1. Select the "Smart Switch" refer to picture 2. Connect the Wi-Fi refer to picture 3.

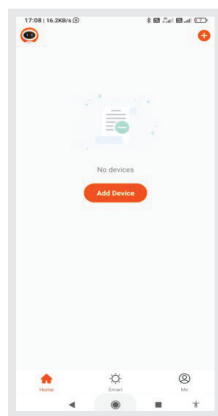

Picture 1

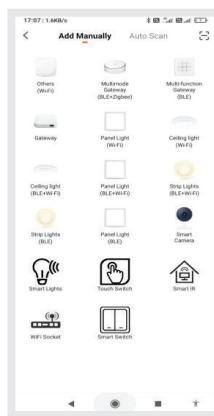

Picture 2

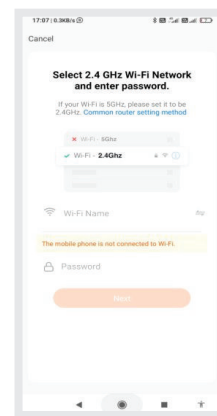

Picture 3

**Step 4:** After connecting the Wi-Fi, click "Next", if the red indicator already blinks, the device will be added soon.

If the red indicator doesn't blink, you can add the device and according to the instructions refer to picture 4 & 5 & 6.

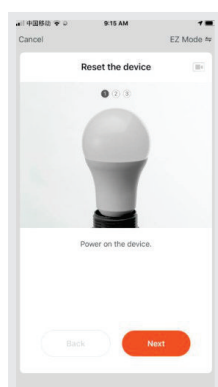

Picture 4

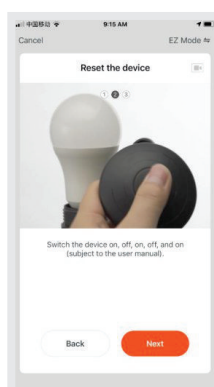

Picture 5

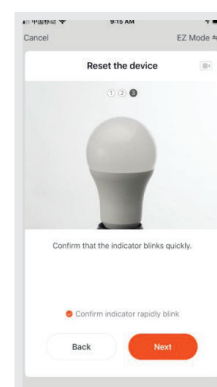

Picture 6

**Step 5:** When the device and WIFI are successfully connected, you will see a list of devices as in picture 7. You can select one device and define the name as you need, then can see the page refer to picture 8.

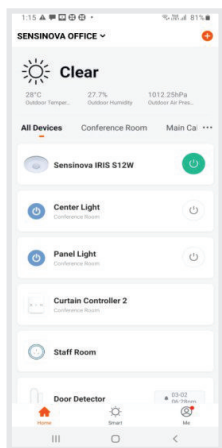

Picture 7

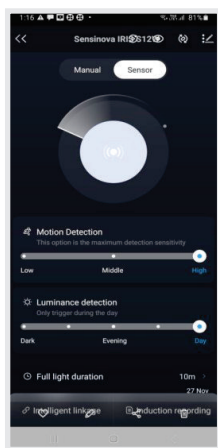

Picture 8

**Step 8:** Remove Device. Refer to picture 10. Click the top right corner, on the page end you can see the "Remove Device". refer to picture 11 & picture 12, Click it and select "Disconnect" and wipe data, the device can be removed and all the settings return to the factory mode. If you switch off the power supply/WIFI, all the current settings are saved.

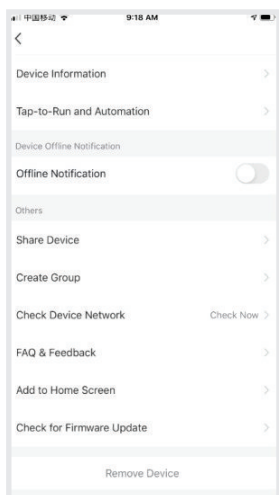

Picture 11

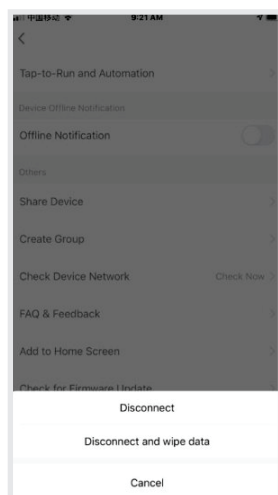

Picture 12

**Step 6:** Click on the device you selected. In "Manual" mode, it's like the normal switch. Click the power button in the middle of the page, you can turn on /off the lamp. Refer to picture 9. Slide "Manual" to "Sensor", it will be changed into the automatic mode.

**Step 7:** In automatic mode, click on the page to adjust the function. You can adjust and set "Motion Detection", "Luminance detection", "Full light duration", refer to picture 10.

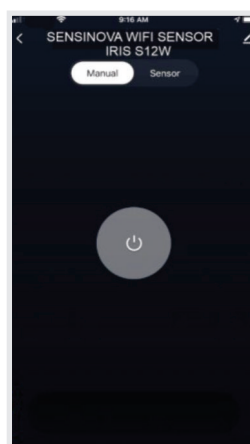

Picture 9

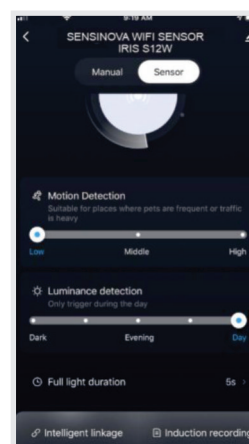

Picture 10

**Step 9:** How to set several mobiles to control one device. Firstly you should finish the APP registration for the mobiles, then can do the next. Refer to picture 1, click the left bottom "ME" then click "Home Management", you can add the members. Also, you can set some other details. Or refer to picture 11, select "Share Device" to add the members.

## CONNECTION

- Please move the upper cover with an anti-clockwise whirl as per the diagram on the right.
- Connect the power and the load according to the connection-wire diagram.
- Fix the bottom on the selected position with the inflated screw.
- Install back the upper cover on the sensor, then you could switch on the power and test it.

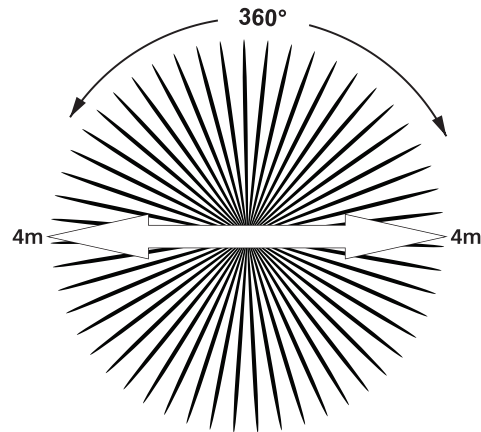
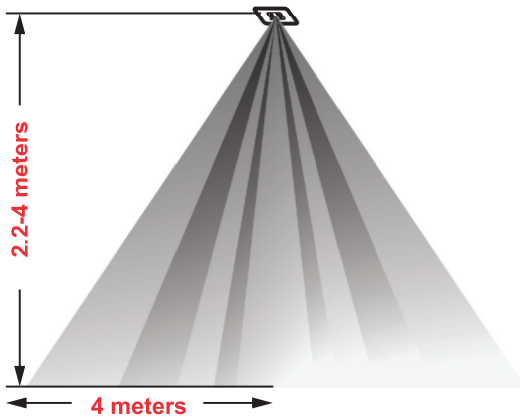
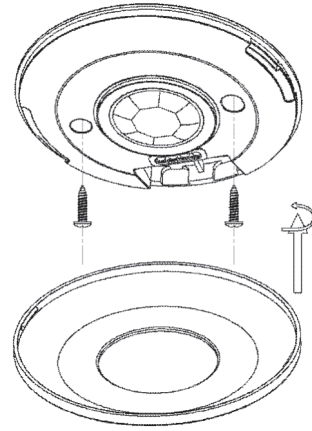

## CONNECTION-WIRE DIAGRAM

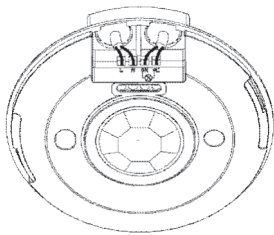

The wires come in and out from the bottom

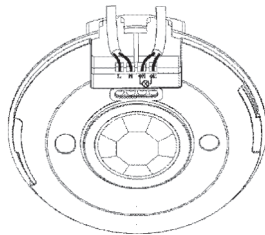

The wires come in and out from the side

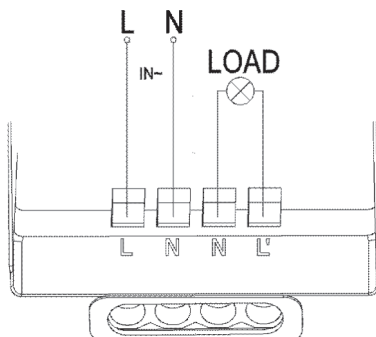

## PRODUCT SIZE DIAGRAM

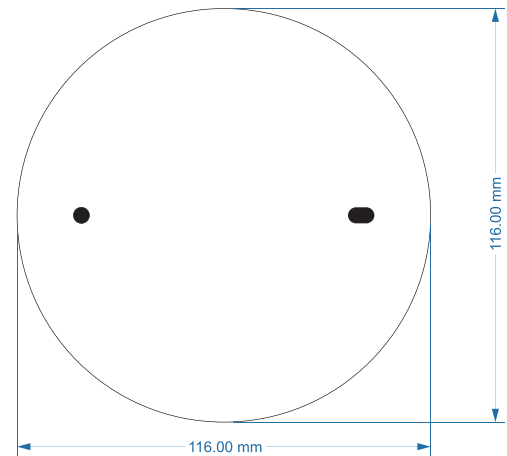

**Note:** When testing in daylight, please turn LUX knob to (SUN) position, otherwise the sensor could not work!

## NOTE

- An electrician or an experienced human can install it
- It cannot be installed on an uneven and shaky surface
- There shouldn't be any obstructive objects in front of the sensor that affect its detection
- Avoid installing it near the metal and glass as they may affect the sensor
- Please don't open the case if you find a hitch after the installation for your safety

## TEST

Slide the "Manual" to "Sensor", it will be changed to the automatic mode.

### Motion Detection:

It has 3 levels, "Low", "Middle", "High", "Slide" to "High", the detection distance can reach to the max 8m.

### Luminance Detection:

It has 5 levels, "Dark" (5LUX), 10LUX, "Evening" (50LUX), 150LUX, "Day" (2000LUX). Slide to "Day" (2000LUX), it can work all day.

### Full light Duration:

Click it to adjust the time from 5s to 60min. Select 5s, if the sensor receives the induction signal, the lamp will be turned on. While there is no other induction signal anymore, the load should stop working within 5s and the lamp would be off.

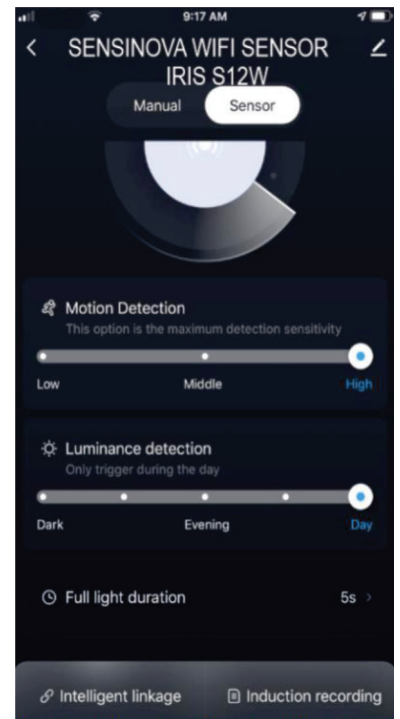

## SOME PROBLEM AND SOLVED WAYS

### The load does not work:

1. Please check if the connection of the power source and load is correct.
2. Please check if the load is good.
3. Please check if the settings of working light correspond to ambient light

### The sensitivity is poor:

1. Please check if there is any hindrance in front of the detector to affect it to receive the signals.
2. Please check if the ambient temperature is too high.
3. Please check if the induction signal source is in the detection field.
4. Please check if the installation height corresponds to the height required in the instruction.
5. Please check if the moving orientation is correct.

### The sensor can not shut off the load automatically:

1. Please check if there is a continual signal in the detection field.
2. Please check if the time delay is set to the maximum position
3. Please check if the power corresponds to the instruction



C K Patel Estate, Survey Number 372, Opp  
Tata Motors Service Centre, Near Rama Kaka  
Deri, Chhani, Vadodara – 391740



+91 9586884885



+91 9979764665



info@sensinova.in



www.sensinova.in