

TECHNICAL DATA SHEET



NANO HB20 (Microwave Motion Sensor)

IP65

4-15m

360°

The product is a new saving-energy switch; it adopts microwave sensor mould with high-frequency electro-magnetic wave {5.8GHz} and integrated circuit. It gathers automatism, convenience, safety, saving-energy and practicality functions. The wide detection field depends on detectors. It works by receiving human motion. When one enters the detection field, it can start the load at once and identify automatically day and night. Its installation is very convenient and its using is very wide. Detection is possible to go through doors, panes of glass or thin walls.

TECHNICAL SPECIFICATION

Power Source:	120-277 V/AC
Power Frequency:	50/60Hz
Detection Angle:	360°
Detection Range:	50%, 100%(choice)
Daylight sensor:	2lux, 10lux, SOLux, 2000lux (choice)
Detection Distance:	4-10m (radius), adjustable
HF System:	5.8GHz CW radar, ISM band
Transmission Power:	<0.2mW
Power Consumption:	approx 0.9W
Hold Time:	5s, 30s, 90s, 3min, 5min, 10min, 20min, 30min (choice)
Installing Height:	4-15m
Detection Motion Speed:	0.6-1.5m/s
Stand-by Period:	10s, 1min, 5min, 10min, 30min, 60min, +∞, 0s
Rated Load:	(choice Max.1200W (220-277V/AC), 800W (120V/AC), 800W (220-277V/AC), 400W (120V/AC)

FUNCTION

- Can identify day and night: It can work in the daytime and at night when three knobs are on above position (Daylight Sensor 2000Lux). It can work in the ambient light less than 2LUX when three knobs are on below position (Daylight Sensor 2Lux). As for the adjustment pattern, please refer to the testing pattern.
- Hold time is optional. It can be set according to the consumer's desire. The minimum time is 5sec. The maximum is 30min.

INSTALLATION

- 1) Loosen the screw on the bottom and unload the bottom (refer to the figure1).
- 2) Pass the power wire through the hole with gasket in the bottom. Connect the power wire into connection-wire column according to the connection-wire diagram.
- 3) Fix the bottom with inflated screw on the selected position (refer to the figure2).
- 4) Install back the sensor on the bottom, tighten the screw and then test it.

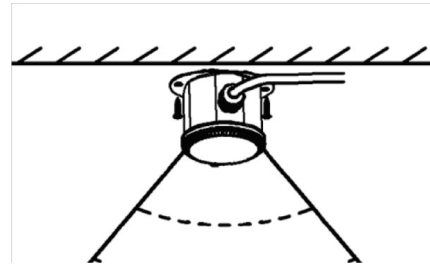
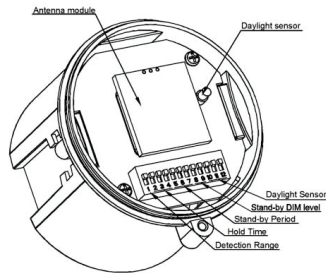

Fig 1

CONNECTION WIRE DIAGRAM APPLICATION

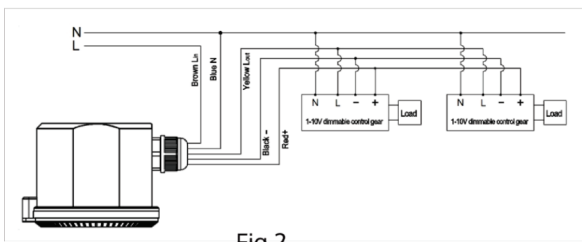
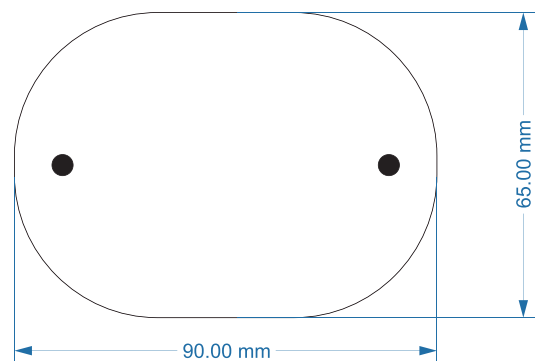

Fig 2

Note: When testing in daylight, please turn LUX knob to (SUN) position, otherwise the sensor could not work!

PRODUCT SIZE DIAGRAM



CALIBRATION

- 1) Sensitivity:** Reach is the term used to describe the diameter of the more or less circular detection zone produced on the ground after mounting the sensor at a height of 2.5 to 6m. Turn the reach control fully anti-clockwise to select minimum reach (approx. 2m dia), and fully clockwise to select maximum reach (approx. 16m dia). Adjust according to locations and site requirements.
- 2) Time Setting:** The light can be set to stay ON for any period of time between approx. 10sec (turn fully anticlockwise) and a maximum of 12min (turn fully clockwise). Any movement detected before this time elapse will re-start the timer. It is recommended to select the shortest time for adjusting the detection zone and for performing the walk test.
- 3) Light Control Setting:** The chosen light response threshold can be adjusted from approx. 2-2000 Lux. Turn it fully anti-clockwise to select dusk-to-dawn operation at about 2 Lux. Turn it fully clockwise to select continuous daylight operation. The knob must be turned fully clockwise when adjusting the detection zone and performing the walk test in daylight, then adjust setting according to site requirement.

TEST

- Slide the all knobs on "above" position. When you switch on the power, the light will be on at once, and 5 sec later without induction signal the light will turn off quickly. Then if the sensor receives induction signal, it can work normally
- Adjust the stand-by period to "10s", when the sensor receives induction signal, the light will be 100% on 5sec later, the light dims quickly to 10% on for 10sec and then turn off. If the sensor receives second induction signal within the stand-by period, the light will be 100% on.

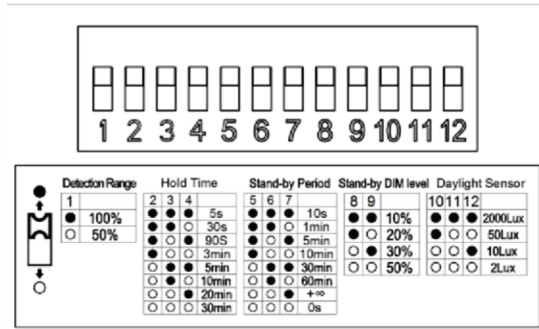
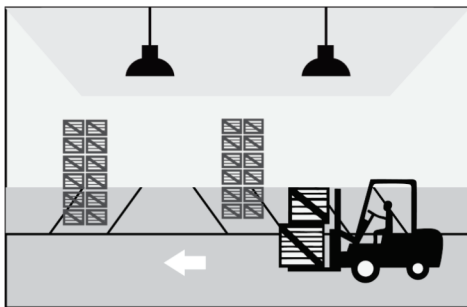

Fig 3

APPLICATION

➤ Daylight Function

It offers 3 levels of light 100 %--> dimmed light (10%, 20%, 30%, 50% optional) -->off; and 2 periods of selectable waiting time, motion hold time and stand-by period; selectable LUX value and choice of detection area.



With sufficient ambient light, the sensor does not switch on the lamp.

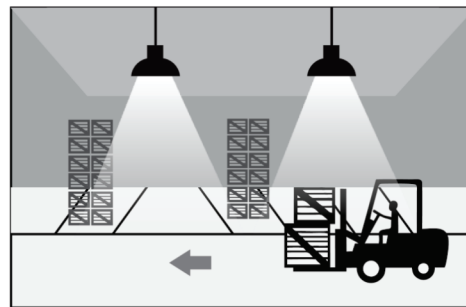

With insufficient ambient light, the sensor switches on the lamp when motion is detected.

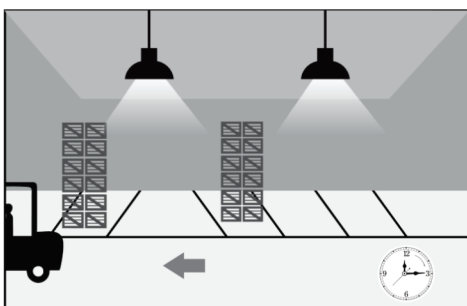

After hold time, the sensor dims the lamp at a low light level if no new motion trigger.

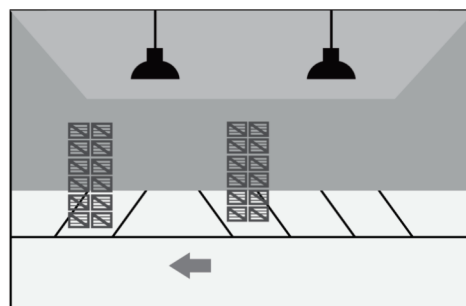

After stand-by period, the sensor switches off the lamp if no motion is detected in its detection zone.

NOTE

- Electrician or experienced human can install it.
- Can not be installed on the uneven and shaky surface
- In front of the sensor there shouldn't be obstructive object affecting detection.
- Avoid installing it near the metal and glass which may affect the sensor.
- For your safety, please don't open the case if you find hitch after installation.
- In order to avoid the unexpected damage of product, please add a safe device of current 6A when installing microwave sensor, for example, fuse, safe tube etc.
- Motion sensor overrides daylight sensor, meaning the daylight sensor starts to check the ambient natural light only when the lamp is switched off (motion hold-time elapsed).
- This 1-10V output is no insulated; please make sure the fixture is constructed according to relevant safety standard.

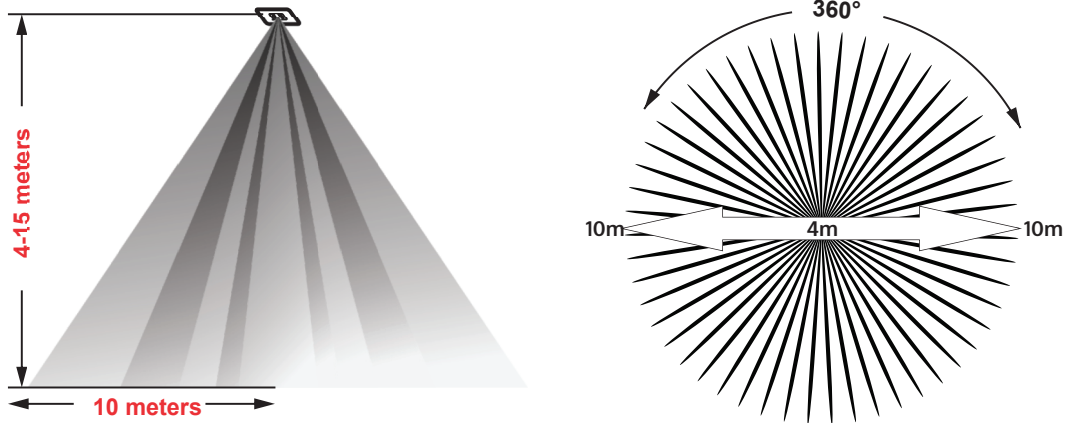

TROUBLESHOOTING

Malfunction	Cause	Remedy
The load will not work	Wrong light control selected Load faulty Mains is switched OFF	Adjust Setting Change Load Switch ON
The load is always on	Continuous movement in detection zone	Check zone setting
The load is ON without any identifiable movement	The sensor not mounted for detecting movement reliably Movement occurred, but not identified by the sensor(movement behind wall, movement of a small object in immediate lamp vicinity etc)	Securely mount enclosure Check zone setting
The load will not work despite movement	Rapid movements are being suppressed to minimize malfunctioning or the detection zone you have set is too small	Check zone setting.

